

Design considerations for an automated production pressure test system



Overview

Industrial Products are designed for the specific requirements of specific applications. An obvious statement – however, it logically leads to the question of what assurance can be provided as to whether a given product in fact meets the requirements of the application for which it is intended? In order to ensure that products will meet the requirements for which they were designed, it is critical to test them in conditions as close to those in which they will operate. Closely reproducing real world environmental conditions and accurately measuring and recording the result to validate performance is critical to safety and quality.

In many cases where tests need to be repeated on a frequent or high-volume basis, there can be many benefits to automating the testing process. By removing possible user error from an input perspective or incorrect analysis of results, automating production testing can produce accurate, reliable and repeatable results. Automated testing is an effective and efficient approach to significantly reducing cost and dramatically improving quality. This is particularly true of measurement and sensing instrumentation where the safe and efficient operation of larger products and systems depend on individual device performance and reliability.

Summary

In this article the various aspects of the design and development of an automated production pressure test system for pressure measurement instrumentation will be examined. While even within the instrumentation subset of pressure measurement, there still can be a wide range of requirements and several different types of devices; pressure gauges (mechanical & electrical), pressure switches, pressure converters and pressure sensors (transmitters and transducers). In order to narrow down the scope of discussion further, the primary focus of this article will be automated systems to test electronic pressure devices, i.e. pressure sensors (transducers/transmitters).



Introduction

Pressure sensors are used in every conceivable environment. From the crushing pressures at the bottom of the ocean on a subsea wellhead to the hardest vacuum of space on a satellite in orbit. Recreating these extremes requires a wide range of different test systems. Covering in this discussion ever unique aspect of this wide range would prove difficult. Fortunately, however, there are components of test systems that are common to the largest majority. Additionally, there are commonalities in the ways these components are integrated to provide the automation aspects of the system(s). In the first portion of this paper an examination of the common critical components that are necessary for a basic system will be discussed. Then, a review of how the components are integrated from mechanical, electrical and software perspectives will be undertaken.

A note of clarification on the difference between design testing versus performance testing. Design or qualification testing is used to validate the product design for purpose. Examples of testing for design elements for a pressure sensor can include; shock & vibration effects, EMI/RFI effects, power supply variation and isolation tests. Other testing may include, but not limited to, destructive testing; overpressure, burst and containment pressure testing and lifecycle testing for example. Once testing is completed to validate design it is not normally repeated on an ongoing basis in production unless called out as part of a specific Performance Acceptance Test (PAT) or Acceptance Test Procedure (ATP). The type of production testing being discussed here is primarily performance testing, i.e. conformance of performance to published data sheet and/or customer agreed specifications.

Testing requirements, as just mentioned, may be determined by the need to meet published data sheet specifications, customer specific requirements or to meet an industry standard. For performance testing of a pressure sensor the primary parameters to simulate and/or control as they have the greatest influence on performance are typically pressure, temperature and electrical (excitation – voltage or current).

An automated pressure test system is potentially used at two points in product testing. The fundamental sensing element of a pressure sensor is not, unfortunately, an 'ideal' device, meaning it does not produce an output that is perfectly linear and accurate in all changing environmental conditions; pressure, temperature, humidity or density. They require some level of correction or compensation to improve performance. The level and sophistication of how this is accomplished depends on how much improvement is desired. So, the test system is employed to collect data on the 'uncompensated' sensor. This data is used to make determinations on what compensation is required. This is done in one of several ways, via a passive/active electrical circuit (e.g. fitted resistors, SOT or laser trim) or a microprocessor-based approach are the two most common. Pressure sensor compensation and associated techniques is a subject unto itself and not the primary focus of this article. There are many good resources for additional information on the topic readily available on the internet. After the compensation is applied, a subsequent performance test is performed using the pressure test system to verify or validate that the compensation performed meets the requirements. These tests may be performed on the same test system but are also often two separate test rigs, the second being the validation or verification system.



Common component instruments

The basic components of an automated production pressure test system normally include but are not limited to the following:

- Pressure controller/calibrator
- Environmental test chamber
- Digital multimeter
- Programmable power supply
- Computer/controller

Reference Figure 1 below:

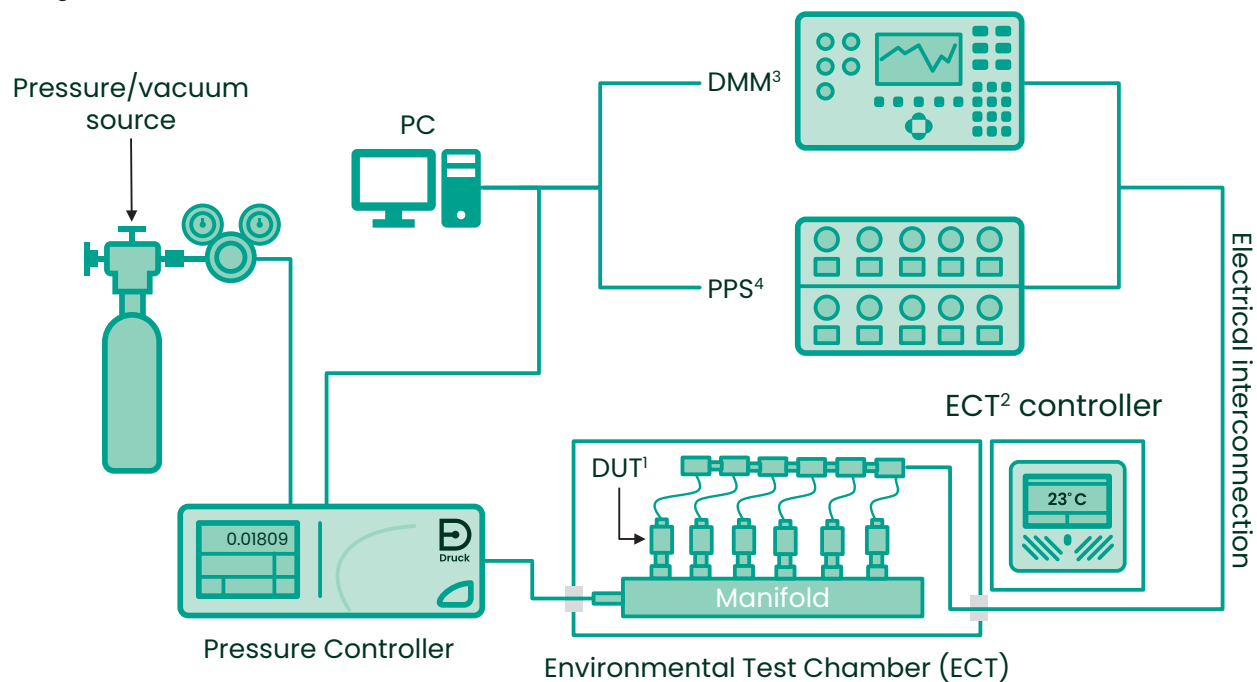

Figure 1. Automated production pressure test system

¹DUT: Device Under Test | ²ECT: Environmental Test Chamber | ³PPS: Programable power supply | ⁴DMM: Digital Multimeter

Component considerations:

Each component will have features and attributes necessary to the test system in total. Because the focus of this discussion is a performance testing system, accuracy and precision are the most critical characteristic of each component. An understanding of these terms and how they relate to the selection criteria for the suitability of a component is vitally important. Since each component is measuring and/or controlling a different parameter there will be variations in the units or percentages, but the underlying definitions will be common to most.

Accuracy

As per the VIM (Vocabulaire International de Métrologie) definition, accuracy is a qualitative term, defined as “closeness of agreement between a measured quantity value and a true quantity value of a measurand.” However, often in industry accuracy is interpreted as a quantitative term. The term “accuracy” should be associated with the specified measurement error, including the impact of systematic error, random error and drift (in cases where accuracy is specified over a period of time).

Definitions of accuracy should consider the application and the needs of the testing requirements. Careful attention should be paid to the drift specification, as many times high accuracy could be claimed at the expense of shorter re-calibration intervals.

Precision

As per the VIM (Vocabulaire International de Métrologie) definition, precision is a qualitative term defined as "closeness of agreement between indications or measured quantity values obtained by replicate measurements on the same or similar objects under specified conditions"

However, often in industry, precision is interpreted as a quantitative term and is an often-misused metrological characteristic by manufacturers of measuring instrumentation and misinterpreted by users of such equipment. Some instruments manufacturers use the term precision to mean accuracy and at other times the term precision is used to describe the precision only at room temperature, ignoring the temperature operating range of the measuring instruments. Furthermore, factors such as pressure hysteresis and non-linearity are sometimes excluded from consideration in the precision specification.

When describing precision, as a good practice the following factors should be included:

- Non-linearity
- Hysteresis
- Non-repeatability
- Temperature induced errors

One way in which the accuracy specification is used to determine suitability of a reference instrument is the Total Accuracy Ratio (TAR). The generally accepted industry practice is that the accuracy of the reference should be at a minimum 4 time better than the device under test (DUT), i.e. a 4:1 ratio. The TAR formula is as follows:

$$TAR = \frac{DUT\ Accuracy}{Reference\ Standard\ Accuracy}$$

As an example, if the test to be performed is on a pressure sensor with a stated accuracy of ±0.1% FS and pressure reference standard of ±0.025% FS, the TAR would be,

$$TAR = \frac{\pm 0.1\% FS}{\pm 0.025\% FS}$$

$$TAR = 4$$

In the example the reference standard would be suitable for this DUT. This is an oversimplified example with the convenient assumption that the full-scale ranges of the DUT and reference standard are the same which is not very representative of an actual situation but hopefully demonstrative of the concept.

Historically using a TAR has been an acceptable methodology. However, with continued improvements in

measurement and sensing technologies leading to higher accuracy devices there has been a need for closer scrutiny of standards being used and the contribution of other potential error sources. Reference standards can be very accurate, but it is a theoretical impossibility for them to represent the exact true value they are used to measure. There is always some question as to how close a standard is to the true value. The questionable amount leads to the metrological concept of uncertainty.

Once again referring to the VIM for the definition:

Uncertainty (of measurement) – non-negative parameter characterizing the dispersion of the quantity values being attributed to a measurand.

This concept is more encompassing of other potential error sources than those included in an accuracy specification and the statistical analysis required to determine probability distributions of those error sources. The primary result of considering uncertainty is the necessary inclusion of the errors associated with a reference standard itself typically expressed as calibration equipment expanded uncertainty.

Note: the concept of uncertainty can be wide in scope. The treatment of the subject in this paper is confined to the types of measurements, relevant instruments and the selection thereof. For a more expansive explanation of the concept please refer to the Guide to the Expression of Uncertainty in Measurement (GUM), JCGM100:2008 – GUM 1995 with minor corrections. Published by the JCGM in the name of the BIPM, IEC, IFCC, ILAC, ISO, IUPAC, IUPAP, and OIML. It is now often referred to as the GUM 1995 with minor corrections.

Incorporation of uncertainty into the decision-making process on the suitability of a reference standard leads to the use of a Total Uncertainty Ratio (TUR) instead of the TAR.

The definition of TUR is:

$$TUR = \frac{DUT\ Uncertainty}{Reference\ Standard\ Uncertainty}$$

The following scenarios demonstrate the use of a TUR to determine the suitability of reference standard:

Scenario 1:

- DUT Accuracy: ±0.25% FS with a full-scale pressure range of 150 psig
- Reference Standard Precision: ±0.01% Rdg + ±0.01%FS with a full-scale pressure range of 300 psi
- Reference Standard Long Term Stability: 0.01% Rdg/annum
- Reference Standard Expanded Uncertainty (k=2): 0.0032% Rdg + 0.7 Pa

In order to use the TUR method, it is necessary to first determine the total uncertainty of the Reference Standard (RS). This would include the precision, stability and expanded uncertainty. Because these influences are uncorrelated the use of a root sum square (RSS) method is justified. The equation is as follows:

Definitions of accuracy should consider the application and the needs of the testing requirements. Careful attention should be paid to the drift specification, as many times high accuracy could be claimed at the expense of shorter re-calibration intervals.

Precision

As per the VIM (Vocabulaire International de Métrologie) definition, precision is a qualitative term defined as “closeness of agreement between indications or measured quantity values obtained by replicate measurements on the same or similar objects under specified conditions

However, often in industry, precision is interpreted as a quantitative term and is an often-misused metrological characteristic by manufacturers of measuring instrumentation and misinterpreted by users of such equipment. Some instruments manufacturers use the term precision to mean accuracy and at other times the term precision is used to describe the precision only at room temperature, ignoring the temperature operating range of the measuring instruments. Furthermore, factors such as pressure hysteresis and non-linearity are sometimes excluded from consideration in the precision specification.

When describing precision, as a good practice the following factors should be included:

- Non-linearity
- Hysteresis
- Non-repeatability
- Temperature induced errors

One way in which the accuracy specification is used to determine suitability of a reference instrument is the Total Accuracy Ratio (TAR). The generally accepted industry practice is that the accuracy of the reference should be at a minimum 4 time better than the device under test (DUT), i.e. a 4:1 ratio. The TAR formula is as follows:

$$\begin{aligned}
 & \text{Total uncertainty (RSS)} \\
 & = \\
 & \sqrt{(\text{Precision})^2 + (\text{Stability})^2 + (\text{RS uncertainty})^2}
 \end{aligned}$$

Because the specification has different expressions of terms, % Rdg, % FS and pressure units (Pa), they cannot simply be plugged into the above equation. It is first necessary to change them into a common expression and then calculate the combined effects. The simplest way in this example is to convert all component to pressure units:

Precision =
 $((\frac{0.01}{100}) \times 150 \text{ psig}) + ((\frac{0.01}{100}) \times 300 \text{ psig}) = 0.045 \text{ psig}$

Long term stability =
 $(\frac{0.01}{100}) \times 150 \text{ psig} = 0.015 \text{ psig}$

Expanded uncertainty =
 $((\frac{0.0032}{100}) \times 150 \text{ psig}) + 0.001 \text{ psig} = 0.0049 \text{ psig}$

With the value in common units, an RSS can now be performed:

$$\begin{aligned}
 & \text{Total Uncertainty (RSS)} \\
 & = \\
 & \sqrt{(0.045 \text{ psi})^2 + (0.015 \text{ psig})^2 + (0.049 \text{ psig})^2} = 0.0477 \text{ psig}
 \end{aligned}$$

The sample calculations above are made at a single reading (indicated value) point of 150 psig. Because the expressions contain a % of reading component, the values will change over the measurement range. It is necessary to consider the values over the whole measurement range. The chart below provides a representative number of measurement points sufficient to determine suitability:

DUT reading (psi)	DUT accuracy (psi)	Required reference standard accuracy for 4:1 Ratio (psi)	Total uncertainty (RSS) (psi)	Total accuracy ratio (TUR)
0	0.3750	0.0938	0.0300	12.50
5	0.3750	0.0938	0.0305	12.29
10	0.3750	0.0938	0.0310	12.09
15	0.3750	0.0938	0.0315	11.89
20	0.3750	0.0938	0.0321	11.69
25	0.3750	0.0938	0.0326	11.50
30	0.3750	0.0938	0.0332	11.31
35	0.3750	0.0938	0.0337	11.13
40	0.3750	0.0938	0.0343	10.94
45	0.3750	0.0938	0.0348	10.77
50	0.3750	0.0938	0.0354	10.59
55	0.3750	0.0938	0.0360	10.42
60	0.3750	0.0938	0.0366	10.26
65	0.3750	0.0938	0.0371	10.10
70	0.3750	0.0938	0.0377	9.94
75	0.3750	0.0938	0.0383	9.78
80	0.3750	0.0938	0.0389	9.63
85	0.3750	0.0938	0.0395	9.49
90	0.3750	0.0938	0.0401	9.34
95	0.3750	0.0938	0.0407	9.20
100	0.3750	0.0938	0.0414	9.07
105	0.3750	0.0938	0.0420	8.93
110	0.3750	0.0938	0.0426	8.80
115	0.3750	0.0938	0.0432	8.67
120	0.3750	0.0938	0.0439	8.55
125	0.3750	0.0938	0.0445	8.43
130	0.3750	0.0938	0.0451	8.31
135	0.3750	0.0938	0.0458	8.19
140	0.3750	0.0938	0.0464	8.08
145	0.3750	0.0938	0.0470	7.97
150	0.3750	0.0938	0.0477	7.86

The TUR at all points across the range is > 4, the worst case is > 7:1, which should provide confidence that this reference standard is sufficient for the testing to be performed. Illustrated graphically:

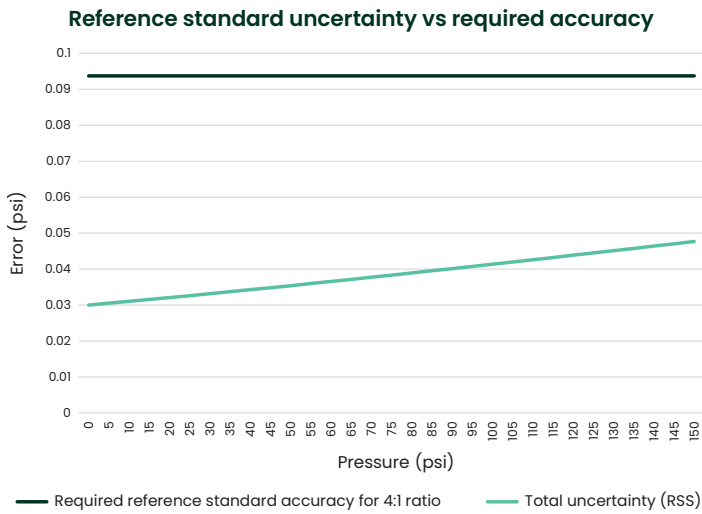

DUT reading	DUT accuracy (psi)	Required reference standard accuracy for 4:1 Ratio	Total uncertainty (RSS) (psi)	Total uncertainty ratio (TUR)
0	0.15	0.0375	0.0300	5.00
5	0.15	0.0375	0.0305	4.92
10	0.15	0.0375	0.0310	4.84
15	0.15	0.0375	0.0315	4.76
20	0.15	0.0375	0.0321	4.68
25	0.15	0.0375	0.0326	4.60
30	0.15	0.0375	0.0332	4.52
35	0.15	0.0375	0.0337	4.45
40	0.15	0.0375	0.0343	4.38
45	0.15	0.0375	0.0348	4.31
50	0.15	0.0375	0.0354	4.24
55	0.15	0.0375	0.0360	4.17
60	0.15	0.0375	0.0366	4.10
65	0.15	0.0375	0.0371	4.04
70	0.15	0.0375	0.0377	3.98
75	0.15	0.0375	0.0383	3.91
80	0.15	0.0375	0.0389	3.85
85	0.15	0.0375	0.0395	3.79
90	0.15	0.0375	0.0401	3.74
95	0.15	0.0375	0.0407	3.68
100	0.15	0.0375	0.0414	3.63
105	0.15	0.0375	0.0420	3.57
110	0.15	0.0375	0.0426	3.52
115	0.15	0.0375	0.0432	3.47
120	0.15	0.0375	0.0439	3.42
125	0.15	0.0375	0.0445	3.37
130	0.15	0.0375	0.0451	3.32
135	0.15	0.0375	0.0458	3.28
140	0.15	0.0375	0.0464	3.23
145	0.15	0.0375	0.0470	3.19
150	0.15	0.0375	0.0477	3.15

Again, it is demonstrated that the accuracy of the reference standard is well below that which is required.

Scenario 2:

- DUT accuracy: $\pm 0.10\%$ FS with a full-scale pressure range of 150 psig
- Reference standard accuracy: $\pm 0.01\%$ Rdg + $\pm 0.01\%$ FS with a full-scale pressure range of 300 psi

In this example the DUT has a higher accuracy. Will the reference standard still be sufficient?

Performing the same calculations as in Scenario 1, summary of results in table below with the new parameters:



And, graphically:

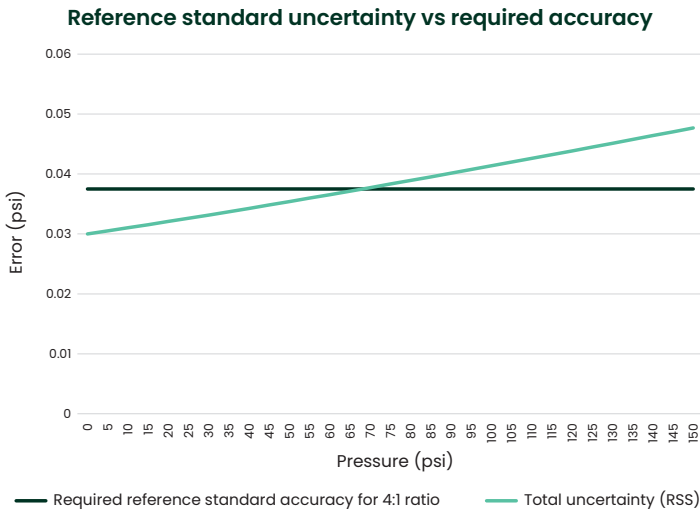

The results highlight that in this example a TUR of > 4 is only maintained for readings up to 65–70 psi. Given this result, a decision would need to be made on suitability of the reference standard. One option is to review a higher accuracy reference standard in order to achieve a 4:1 TUR (Scenario 3). Alternatively, a <4:1 ratio could be deemed acceptable where it is sufficient for the application or customer(s) purpose. It is possible that a DUT has an accuracy level where a 4:1 ratio is not possible to achieve, possibly because an acceptable reference standard is not commercially available or not economically feasible. In this condition recording and reporting of the uncertainties and the achievable ratio may be the best or only option.

Scenario 3

- DUT accuracy: $\pm 0.10\%$ FS with a full-scale pressure range of 150 psig
- Reference standard accuracy: $\pm 0.005\%$ Rdg + $\pm 0.005\%$ FS with a full-scale pressure range of 300 psi

Again, performing the same calculations as in Scenario 1, the results are show on the following chart:

DUT reading (psi)	DUT accuracy (psi)	Required reference standard accuracy for 4:1 Ratio (psi)	Total uncertainty (RSS) (psi)	Total accuracy ratio (TUR)
0	0.15	0.0375	0.0150	10.00
5	0.15	0.0375	0.0153	9.83
10	0.15	0.0375	0.0155	9.65
15	0.15	0.0375	0.0158	9.47
20	0.15	0.0375	0.0161	9.29
25	0.15	0.0375	0.0165	9.11
30	0.15	0.0375	0.0168	8.93
35	0.15	0.0375	0.0172	8.74
40	0.15	0.0375	0.0175	8.56
45	0.15	0.0375	0.0179	8.38
50	0.15	0.0375	0.0183	8.21
55	0.15	0.0375	0.0187	8.03
60	0.15	0.0375	0.0191	7.86
65	0.15	0.0375	0.0195	7.69
70	0.15	0.0375	0.0199	7.53
75	0.15	0.0375	0.0203	7.37
80	0.15	0.0375	0.0208	7.22
85	0.15	0.0375	0.0212	7.06
90	0.15	0.0375	0.0217	6.92
95	0.15	0.0375	0.0221	6.78
100	0.15	0.0375	0.0226	6.64
105	0.15	0.0375	0.0231	6.50
110	0.15	0.0375	0.0235	6.37
115	0.15	0.0375	0.0240	6.24
120	0.15	0.0375	0.0245	6.12
125	0.15	0.0375	0.0250	6.00
130	0.15	0.0375	0.0255	5.89
135	0.15	0.0375	0.0260	5.77
140	0.15	0.0375	0.0265	5.67
145	0.15	0.0375	0.0270	5.56
150	0.15	0.0375	0.0275	5.46



And, graphically:

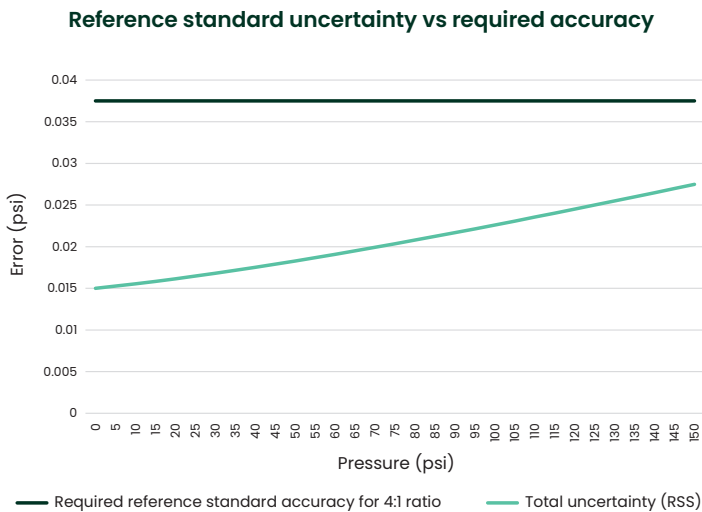

From these results it is demonstrated that a >4:1 TUR can be re-established through the selection of a higher accuracy controller.

It should be noted that the requirements of production testing do not normally require an accredited calibration. An accredited calibration is one in which the calibration and/or metrology laboratory conforms with the strict requirements of international standards, i.e. ISO 17025, possibly ANSI Z540.3 for North America. These standards define specific guidelines for uncertainty analysis and reporting.

As previously stated, the evaluation of the suitability of a reference instrument/standard used in the above examples were for a pressure reference standard. The methodology and process would be the same, or at least very similar, for other component instruments to be used in a test stand.

Pressure controller

Because the pressure controller of an automated pressure test system in large part defines the quality of measurement that can be made and subsequently how well the test can be performed, it is the most critical component and requires the most careful consideration.

In addition to the accuracy and uncertainty considerations discussed in the previous section there are several other aspects of the pressure controller to consider.

Pressure range – Pressure range selection of the pressure controller should align with the pressure ranges of the devices to be tested. As discussed, the accuracy of the pressure controller is, or can be, in part or in total, a function of the full-scale pressure range. Often, a pressure test stand needs to incorporate the flexibility to cover a wide band of pressure ranges. In order to maintain an acceptable TUR, multiple controllers with different full-scale pressure ranges may need to be integrated. Or, alternatively, having multiple test stations for different pressure ranges may be a better option.

Speed to set-point – how quickly can the controller reach and provide a stable pressure at a desired set-point? In a

production environment, throughput is a key performance indicator. Minimizing the time to set-point decreases the total testing time which increases throughput. When the number of sensors on a given test (there are typically multiples), the number of test point and the aggregate total over time, even a few seconds improvement on speed to set-point can make a significant difference. Apart from critical to quality factors, i.e. accuracy, and all else being equal, speed to set-point could be the most critical element of the decision-making criteria.

Control stability – how stable does the controller hold the set-point once it is reached? In order to take an accurate measurement, it is important that the pressure does not vary when taking the reading. Variation of pressure due to instability in the controller can potentially add another element of error. Note: Control Stability is different than the measurement stability discussed in the previous section on accuracy and uncertainty. Measurement stability is a result of possible drift in the reference sensor over time.

Reliability/ruggedness – While there is not necessarily a specification for reliability or ruggedness, there are differences in the design purposes of different controllers. Some controllers are made for a metrology or calibration laboratories to help automate the calibration process of other transfer standards. Calibration laboratories are typically controlled environments where the relative volume of calibrations is small so performance aspects such as accuracy are critical but aspects like speed are not. Production environments can be less friendly to instrumentation and the volume of calibrations can be high. Controllers in production application can run a full 8-hour shift, sometimes 2 shifts, 5+ days a week. Controllers not designed for the environment or these types of duty cycles can require a higher level of maintenance and care increasing downtime, decreasing throughput and ultimately costing time and money.

Computer Controlled – The ability to control a pressure controller via computer is critical to automating a testing system. Consider what computer interface options are planned for testing system, e.g. RS232, IEEE, Ethernet, USB, and ensure the controller selected supports the requirement.

Environmental chamber

An environmental chamber provides a controlled space in which sensors are placed to simulate ambient temperatures, and possibly humidity, to which sensors will be exposed in actual use. There are number of consideration specific to the selection of an environmental chamber:

Size/volume

- How big does it need to be to accommodate test device(s)?
- What is the size of the device itself?
- How many are to be tested at one time?
- How big is the fixturing? e.g. manifold, interconnects, cabling, etc.
- A working rule-of-thumb is that the chamber volume should be 3-5 times the volume of the test items total volume

- Ports/Pass-Through's – how much area is needed for running items (cabling, tubing/hoses) into and out of the chamber. How to seal pass-thru and items in order to maintain temperature is an important consideration.

Temperature range

What are the temperature range(s) to which test device will be exposed?

Do Testing requirements exceed actual product specifications?

Temperature control

- Tolerance
Does the chamber temp need to be controlled to specific temp and tolerance? Or, is a reference temperature sufficient for sensor compensation/calibration and therefore sufficient that it can be accurately measured and recorded?
- Uniformity
Will temperature gradients within Chamber have an adverse effect on test?
- Stability
How stable does the chamber temperature need to be and for how long?
- Settling time
Consider that the chamber may have a settling time, but also that test units will require some 'soak' time to reach equilibrium with the chamber temperature. Total time is dependent on the size and quantity/volume of DUT's.
- Change rate
Temperature Change Rate of an Environmental Chamber is often the determining factor in how quickly a stable state required for measuring a test point and subsequently the total time of a complete test cycle. Understanding the temperature test profile is important to defining the chamber requirements. It could be advantageous to select a chamber that is capable of fast change rates may be advantageous to reduce test time. But if the profile defines a change rate that requires a slow change rate it may not be worth incurring the additional cost. If a rapid rate-of-change faster than the mechanical refrigeration is required, the addition of liquid nitrogen (LN₂) or carbon dioxide (CO₂) boost can be used.

Humidity range

Humidity may not be critical in pressure test per se, but it is most likely important in terms of preventing conditions that may be undesirable, e.g. condensation or icing, within the chamber. It should be noted that there are some sensor technologies that humidity does affect performance. For these devices' accurate measurement and control of humidity could be critical.

Computer controlled

The ability to control an environmental chamber via computer is critical to automating a testing system. Consider what computer interface options are planned for testing system, e.g. RS232, IEEE, Ethernet, USB, and ensure the controller selected supports the requirement.

Digital multimeter (DMM) or other Data acquisition system (DAQ)

A digital multimeter is used to measure the electrical output of the sensor DUT's. There can be many factors to consider when selecting a DMM. Fortunately, within the scope of this discussion they can be narrowed down to an important few:

Benchtop vs handheld

For ease of integration in addition to the higher level of functionality, such as remote communications to a PC, a benchtop/rack mountable version is recommended over a handheld DMM.

Multichannel capability

The DMM needs to be multichannel with expansion capability to accommodate the number of DUT's intended to be tested at a time. This can also be achieved via dedicated switching systems. e.g. Pickering relays. Some DAQ's have this integrated capability as well.

Display

Because the DMM will be controlled by and measured values read into the controlling software a display is not strictly required. The type of display and the quantity of information that can be shown is more a determination of individual/organization preferences. The preference of having a local display could be for the simple purpose of knowing your setup is running when walking past the equipment or to possibly the ease of trouble shooting locally.

Accuracy, digits and resolution

The concepts and selection criteria discussed in earlier section should apply similarly to the DMM.

Digits and subsequently the resolution achievable relate to parameters of the display. The number of digits of the display determines the number of counts which are determinant in the resolution. Resolution needs to be greater than the least significant digit of the accuracy.

Digital sensor communication interface

Many of today's sensors work by communicating over a communications protocol rather than an analog output; e.g. RS232, I2C, SPI, CANBus, Modbus, Profibus, HART, FFB, to name a few. It may be the case that your DMM can be replaced by a piece of hardware that is capable of multiplexing several I2C sensor outputs (for example) and so it is therefore important to understand the output signal generated by the sensor being tested.

Computer controlled

The ability to control a DMM or DAQ via computer is critical to automating a testing system. Consider what computer interface options are planned for testing system, e.g. RS232, IEEE, Ethernet, USB, and ensure the controller selected supports the requirement.

Programmable power supply (PSU)

Linear vs switching?

While many PSU manufacturers identify linear vs switching as an important selection criterion, and it may well be for many applications, from an automated test system perspective it is not highly critical. Both offer relative advantages, and either may be suitable. Switching supplies offer higher efficiency, smaller size and flexibility. However, linear supplies typically offer better regulation and lower noise and so, all other things being equal, would be the default recommended option for test systems. In this instance, it is important to consider the sensor voltage and current requirements so as not to exceed any power supply ratings (VA).

Transient response

Fast transient response may be essential due to the current-draw profile of a typical sensor whereby "gulps" of current are drawn when readings are transmitted. The higher the number of sensors being powered simultaneously is more likely to result in the requirement for faster transient response.

Noise/ripple

Minimizing noise and ripple as much as possible is particularly important in the compensation phase of sensor production as it is critical to make sure any signal output changes are due to actual pressure changes and not electronic noise

Load regulation

Maintaining an accurate output voltage when the overall load is subject to change is important throughout all stages of testing (especially if the sensor being tested is susceptible to supply voltage variation). It is important to ensure the load regulation guaranteed for the power supply is not going to affect the error budget of the sensor under test.

Line regulation/stability

This parameter would not usually be considered too important unless the supply voltage feeding the power supply itself is

particularly poor from a stability perspective. If this is the case, then you should ensure that the quoted line regulation figure is not going to affect the error budget of the sensor under test.

Constant voltage/constant current

Pressure sensors can be excited with either constant current or constant voltage sources. Most PSU's of suitable performance level are also capable of both but an item to confirm. For constant current, things are more complex – it may be necessary to build a multi-channel constant current supply.

Computer controlled

Most PSU's have digital interfaces like the other instrument components discussed. While many suppliers provide some level of software, mostly all of them can again be programmed using standard SCPI commands or similar (see Software Integration section for more detail). This is crucial if a completely automated system is required.

Additional notes/best practices

- If DUT's are ratio metric devices the output voltage should be measured as part of the test cycle. Do not rely on the PSU setting, read back on calibrated DMM
- Add current limit – always set the current limit to typically 2 times
- the expected current to detect faults. For multi-channel setups, individual current limits will prevent single sensor failure from upsetting entire calibration run. This may again require incorporating some additional circuitry but will act as safeguard against production yield loss.

Integration

Software integration

Perhaps the first and biggest decision to make regarding software is 'Make' vs Buy decision, i.e. write your own or buy it. Buying could mean either purchasing an existing calibration software package or hiring a consultant to write it. There are many fine calibration software products available on the market today which could be integrated to control an automated production pressure test system. However, most are oriented towards calibration management in a calibration lab where calibration volume is low in relative terms to a production environment. Integration and modification costs could be high as well as increasing project timelines.

Fortunately, many of the components of a pressure test system have relatively straightforward and easy to use computer interfaces, certainly more so than in years

past. These capabilities allow for control of the individual components from software. A standard protocol, Standard Commands for Programmable Instruments (SCPI, pronounced 'Skippy'), exists and has been adapted by many manufacturers of test instrumentation. So, if an organization

SCPI Consortium – The Standard Commands for Programmable Instrumentation (SCPI) Consortium was an organization whose members shared a common commitment to develop a common interface language between computers and test instruments. The SCPI Standard is built on the foundation of IEEE-488.2, Standard Codes and Formats. It requires conformance to IEEE-488.2 but is pure software standard. SCPI syntax is ASCII text, and therefore can be attached to any computer test language, such as BASIC, C, or C++. It can also be used with Test Application Environments such as LabWindows/CVI, LabVIEW, MATLAB, Microsoft Visual Studio, or Agilent VEE. SCPI is hardware-independent. SCPI strings can be sent over any instrument interface. It works equally well over GPIB, RS-232, VXIbus or LAN networks. (ref. <https://www.ivifoundation.org/scpi/default.aspx>)

Mechanical integration

Pressure/vacuum source – Pressure Controllers do not typically have an internal pressure generation capability. They require an external pressure source. Most often the pressure source is a compressed gas cylinder. Because a controller typically employs solenoid valves to bleed on and bleed off pressures, it is good practice to minimize any potential contaminants (e.g. dirt, oil/grease, moisture) that could interfere with their proper operation. The type of gas is not critical if it is clean and dry. Nitrogen is a common choice, an inert gas that even in an industrial grade is supplied to a 99.998% purity level for relative low cost making it a good option. Instrument grade air is used but it would be recommended that proper care is taken, via appropriate filters and/or moisture traps, to ensure that any moisture or contaminants would be prevented from entering the system. Filters are cheap compared to the damage that can be caused by debris.

If test requirements include vacuum ranges (negative gauge ranges) most controllers can perform this function as well. Controllers would similarly need an external vacuum source to do this. There are many quality vacuum pumps available for this usage, the type and quality of pump would be dependent on the level of vacuum a test requires. Again, care and consideration would need to be taken in protecting the controller from any contamination or moisture ingress. A scenario in which inadvertent damage to the pump can occur is when venting down from high pressure, a 1 psi blow off valve is recommended (Fig 2-4).

Note: safety – All plumbing must be rated to the max working pressure of the system, be appropriate for the environment and be installed in accordance with local regulations.

An example of pneumatic connections with a positive pressure and vacuum supply is shown in the diagram below:

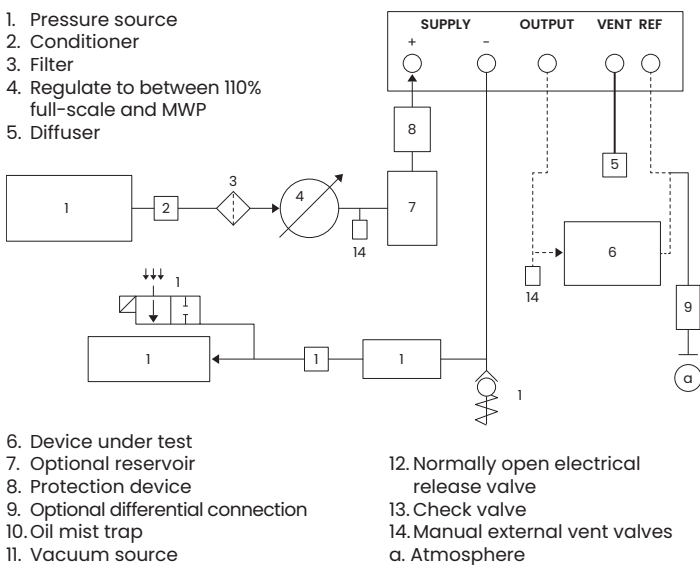
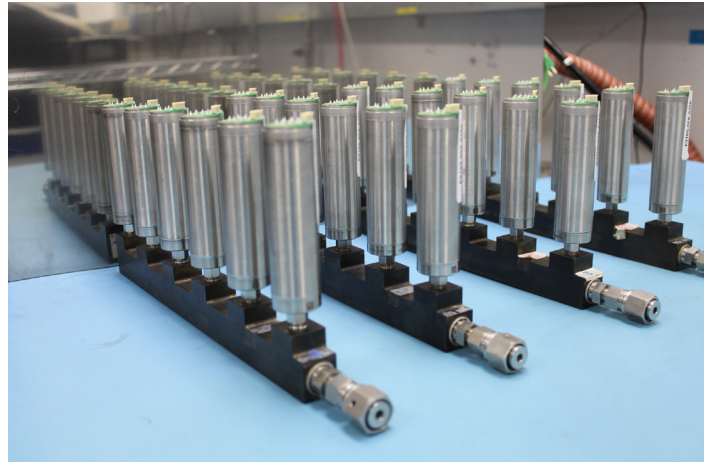

Figure 2-4. Pneumatic connections with vacuum supply

Mechanical pressure interconnects

As previously discussed, in a production test situation where a number of sensors are being built and tested at the same time, it is necessary to fixture to be able to apply pressure to multiple DUT's simultaneously. This is typically done with a pressure manifold that has the require number of test ports. Pressure is applied to the volume within the manifold. Fittings and sealing method must be suitable for pressure and temperature range. As is often the case that you get what you pay for. High quality pressure connectors are expensive but, over time, will be worth the investment.



Picture 1: A typical pressure test manifold

Electrical interconnects

The electrical connections also need to be able to accommodate multiple DUT's to supply excitation voltage and read outputs. While the excitation voltage, or possibly current, are the same the output of each individual sensor will vary. This make is necessary to have discrete connections for each sensor to connect to an input channel on the multimeter.

As a similar comment to Mechanical component, again very much a case of getting what you pay for. High quality electrical interconnections are more expensive but will prevent production yield and/or downtime issues.

Best practice notes:

- For best results on ratio metric sensors, sensor excitation must be measured local to sensor to remove the effect of wiring resistance.
- Separate current limits and independent wiring on each channel prevents single sensor failure from affecting all units.

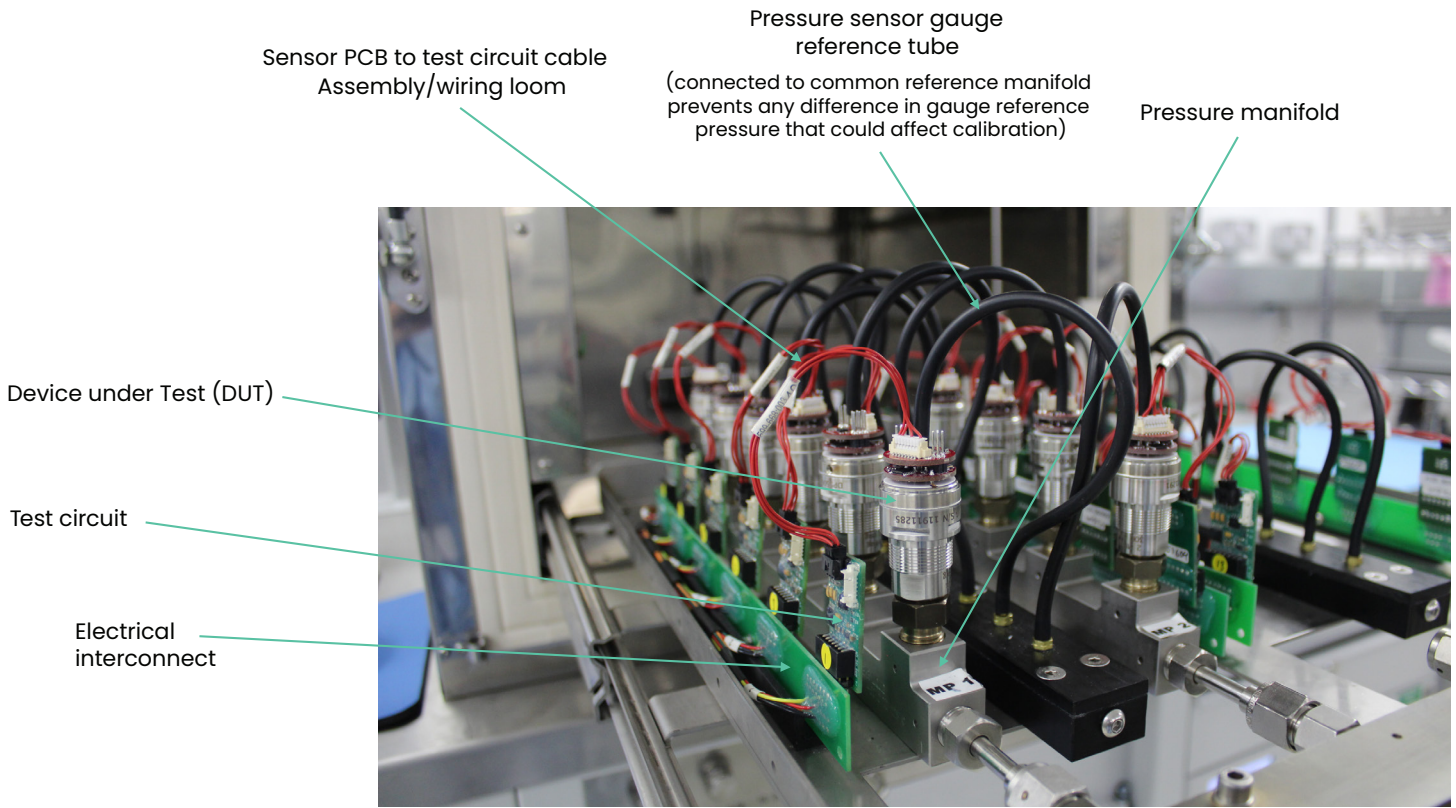

Picture 2: A typical test set-up illustrating sensors connected to electrical interconnects.

Housing – rack/bench/cabinet/other

The ‘architecture’ of the layout of a test system does not need to conform to any prescribed format. And different components may need to be addressed differently. The most common housing arrangement for the measurement instruments (pressure controller, PPS, DMM and PC) is to be rack mount. Most of the instruments either are supplied as 19” rack mountable or have some option to do so. The environmental chamber location will depend on the chamber size and services required. Some may be of a size that can fit into a rack or on a benchtop, other may be free standing. Permanent mounting (e.g. in a rack or other enclosure) is likely to improve reliability and confidence in system performance as interconnections are subject to less disturbance.

Conclusions

Designing, building, validating and implementing an automated test system is a significant effort, and highly front loaded at that. There are clearly many aspects to consider and every system likely has some unique or specific requirements. However, with the time and proper attention to detail, the returns on productivity, reliability, quality and safety make it worth the effort.

By first clearly understanding the performance parameters of the product to be tested then clearly defining the test requirements around those parameters a foundation for the selection of components and their integration can be developed. Following this logical, step-wise process will focus the scope and subsequent efforts leading to the successful development of the best possible automated testing solution.



Picture 3: A typical Automated Production Test System

Afterword

There is no shortage of information available to help in making determinations as to what may work best for a particular company, product and application. Hopefully, the information covered here offers some guidance. It is difficult, if not impossible, to capture all the possible considerations and detail so seeking out other sources of information will be necessary. The internet can be a tremendous source in this regard but consider again that it is difficult to capture the decades of hard-won experience most manufactures have gained in supplying their equipment into these types of systems. There is no substitute for experience, and it is encouraged that this experience should be shared and leveraged.

Company profile

Druck, a Baker Hughes business, delivers world-class expertise, excellence and reliability in the toughest circumstances. Druck's piezo-resistive pressure sensors and test and calibration instruments provide our customers with the highest performance, stability, quality, accuracy and quickest response in any environment.

What began in 1972 as a small business in Leicester, UK has grown into a global pressure-measurement business recognized as a world leader serving a wide range of applications for customers in more than 70 countries.

Druck's high-quality products develop from the raw processing of silicon to delivering the final product.

While the initial focus in the early years was on pressure sensors, as the demand for Druck pressure sensors grew so did the need to expand and improve the efficiency of production to keep up. This need led to the in-house development of the first automatic pressure controller. When it was decided to offer this controller as a commercial product to our customers as the DPI 500 in 1979, it's high accuracy, speed, stability and reliability made it an instant success.

There have been many lessons learned and improvement made over the years, not only from our own implementation into our production test systems but also from feedback of our customers. The combined sum of this knowledge and experience is incorporated into not only our current PACE series controller product portfolio, but in our ability to support customers in achieving their testing goals.

Authors and contributing editors

Stephen Sajben, Senior Product Specialist

Neculai Moisoi, PhD, Senior Metrologist

Brian Rhodes, BEng(hons) CEng MIET,
Principal Electronic Engineer

Tom Pigginn, MEng CEng MIET, Lead Pressure Controllers Designer

Timothy Sparkes, IEng MIET, Capability Development Leader

Steven Price, Design Engineer

Specials thanks for creative contributions to:

Fernanda Danielle Rodrigues, Druck Marketing Manager

Serena Gendu, Marketing Intern